

2mm Double-Row Connector (Product Compliant to UL/CSA Standard)

DF11 Series

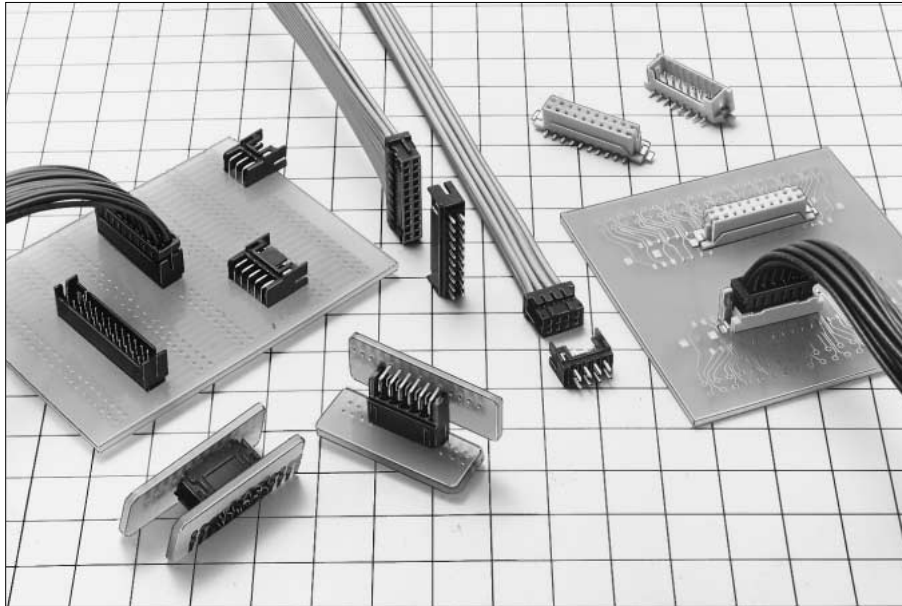

■ Features

1. Space-saving on Board Realized

Double rows of 2mm pitch contact has been condensed within the 5mm width.
The multiple number of signals can be secured in the same space as the conventional 2mm single-row contact.

2. Broad Variation

The insulation displacement and crimping methods are prepared for connection. Thus, board to cable, in-line, board to board connectors are provided in order to widen a board design variation.
In addition, "Gold" or "Tin" can be selected for the plating according application, while the SMT products line up.

3. Applicable Wire Covers Wide Range

According to the double rows of 2mm pitch compact design, the applicable wire can cover AWG22~30.

4. The ID Type Connector Achieves Connection Work.

Using the full automatic insulation displacement machine, the complicated multi-harness can be easily connected, reducing the man-hour and eliminating the manual work process.

■ Applications

Business equipments such as copy machine, printer and so on.

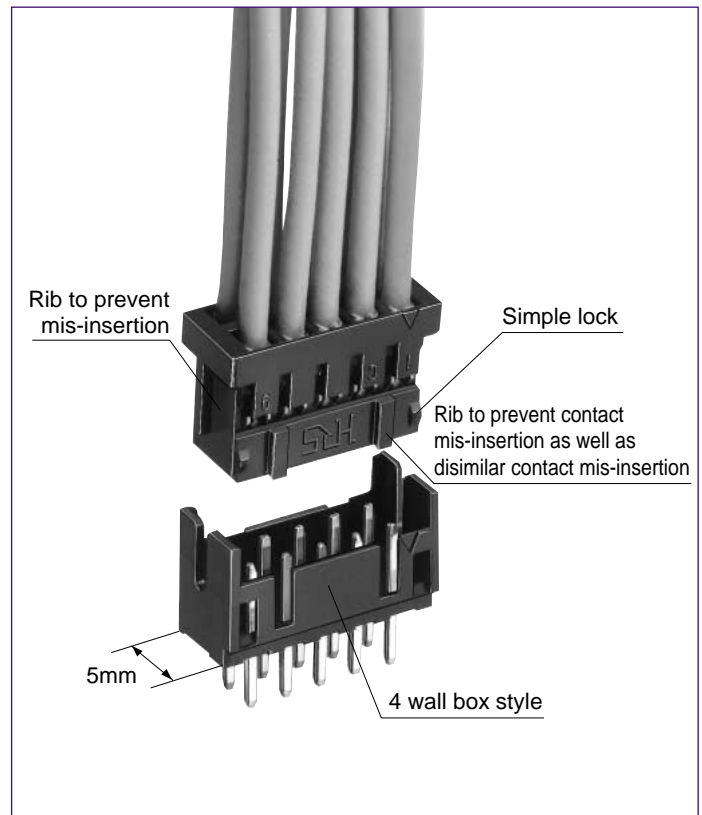

■ Features of DF11 Insulation Displacement Machine (Single Core Punching Full Automatic ID Machine AM700/DF11)

● 5 Major Features of ID Machine AM700/DF11

1. Perform the multi-harness.
2. The setup time has been widely reduced. (10 minutes maximum)
3. Space saving design.
(About half space compared with the conventional machine)
4. Minimize initial cost with low cost.
5. The harness data can be saved in the floppy disk and easily changed.

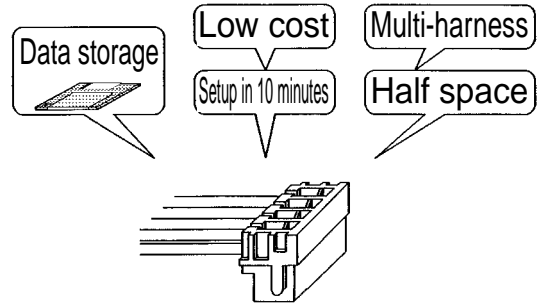

■ Points

Since the DF11 insulation displacement allows double rows ID with a single part, the harness service is completed with machine connection only.

■ Product Specifications

Rating	Rated Current Note 1	Crimping	Wire size	AWG 22~26: 2A	Operating Temperature Range	-30~85°C Note 2
		Insulation Displacement	Wire size	AWG 28 : 1A AWG 30 : 0.5A	Operating Humidity Range	40~80%
	Crimping		250V AC	Insulation Displacement	100V AC	Storage Temperature Range
	Rated Voltage				Storage Humidity Range	40~70%

UL-CSA Safety Standard Approved Specification			
Rating	Rated Current	Wire size	AWG 22 : 2A AWG 24~28: 1A AWG 30 : 0.5A
	Rated Voltage		30V AC

■UL-CSA Safety Standard File No.
UL :E52653
CSA :LR95109

Item	Specification	Condition	
1. Insulation Resistance	1000MΩ min.	Measured at 500V DC	
2. Withstand voltage	Neither short or insulation breakdown	650V AC for 1 minute	
3. Contact Resistance	30mΩ max.	Measured at 100mA	
4. Single Insertion/Extraction Force	0.3N (30gf) min., 4.4N(450gf) min.	Measured by the square steel-made pin of 0.5±0.002mm	
5. Vibration	Electrical discontinuity, 1μS max.	10~55Hz and single amplitude 0.75mm in 3 directions for 2 hours, respectively.	
6. Moisture Resistance	Contact resistance: 30mΩ max. Insulation resistance: 500MΩ min.	Exposed to temperature 40±2°C and humidity 90~95% for 96 hours	
7. Temperature Cycle	Contact resistance: 30mΩ max. Insulation resistance: 1000MΩ min.	(-55°C: 30 minutes → 15~35°C: 2~3 minutes 85°C: 30 minutes → 15~35°C: 2~3minutes) 5 cycles	
8. Operating Life	Contact resistance: 30mΩ max.	Tin plating: 30 cycles Gold plating:50 cycles	
9. Resistance to Soldering heat	No resion area fusion to degrade performance	DIP type	Reflow : 250°C for 10 seconds Manual solder : Soldering iron temperature 300°C for 2 seconds
		SMT type	Reflow : According to the recommended temperature profile Soldering iron temperature : 300°C for 3 seconds

Note 1: Temperature rise included when energized

Note 2: This storage indicates a long-term storage state for the unused product before the board mounted.

The operating temperature and humidity ranges are applied to the non-energized state after the connector has been installed to the board.

Note 3: The above standards represent this series. Individual formal agreement should be based on the "Specification".

Note 4: The above standards represent this series. The Individual formal agreement should be based on the Specification.

Material

Product Type	Part	Material	Finish	Remarks
Crimping Socket	Insulator	Polyamide	Black	UL94V-0
Crimping Contact for Socket	Contact	Phosphor copper	Tin plating or gold plating	————
ID Socket	Insulator	Polyamide	Black	UL94V-0
	Contact	Phosphor copper	Tin plating	————
Receptacle	Insulator	Polyamide	Black	UL94V-0
	Contact	Phosphor copper	Tin plating or gold plating	————
Pin Header	Insulator	Polyamide	Black	UL94V-0
	Contact	Brass	Tin plating or gold plating	————
SMT Header	Insulator	Polyamide	Beige	UL94V-0
	Contact	Brass	Tin plating or gold plating	————
	Metal fittings	Brass	Tin plating	————
In-line Plug	Insulator	Polyamide	Black	UL94V-0
In-line Plug Crimping Contact	Contact	Phosphor copper	Tin plating or gold plating	————
In-line Adaptor	Insulator	Polyamide	Black	UL94V-0
	Contact	Brass	Tin plating	————

Note: HRS tin plating takes action against whisker.

Ordering Information

Please determine the specific product. To order the product, please select products from the product No. as listed in this catalog on page A269~A276.

Connector

DF11 - * **DS** - **2C**
 ① ② ③ ④ ⑤ ⑥

① Series Name : DF	⑥ Connection Form/Contact Style
② Series No. : 11	C : Crimping socket
③ Number of Contacts : 4~32	R26 : Insulation Displacement socket for AWG26
④ Connector Type	DSA: Straight dip
DS : Double Row socket	DS : Right angle dip
DP : Double Row pin header	V : Straight SMT
DEP: Double Row in-line plug	A : Adaptor
⑤ Contact Pitch : 2mm	

Contact

DF11 - **EP2428PCFA**
 ① ② ③ ④

① Contact Type	③ Contact Type/Packaging Type
NONE: For socket	SCF : Socket contact, Embossed tape
EP : For in-line plug	SC : Socket contact, Bag
② Applicable Wire Size	PCF : Plug contact, Embossed tape
22 : AWG22	PC : Plug contact, Bag
2428 : AWG24~28	④ Plating Type
30 : AWG30	None : Tin plating
	A : Gold plating

■ID Socket

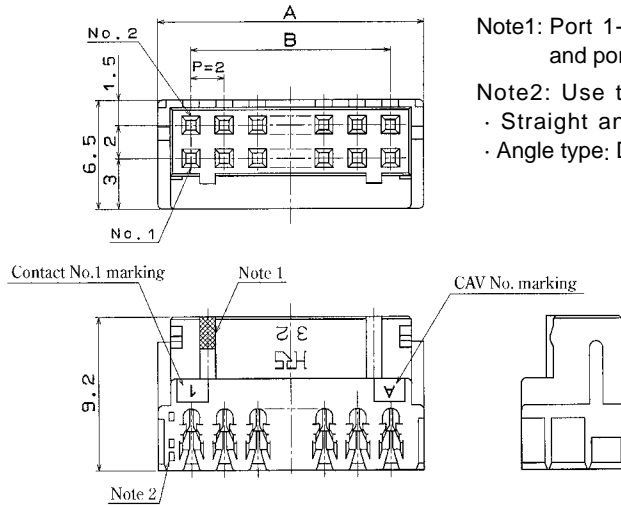
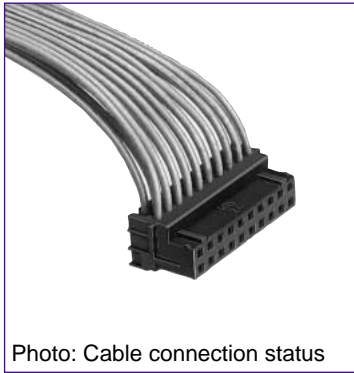

Note1: Port 1-piece indicates odd number row, and port 2- pcs. indicate even number row.

Note2: Use the dip type header as follows.
 · Straight angle type: DF11-※DP-2DSA(08)
 · Angle type: DF11-※DP-2DS(24)

[Specific No.] -※※, (※※)
 None :Tin plating, 100 pcs. per bag
 (21) :Tin plating, Tube packaging

Unit: mm

Product No.	HRS No.	Number of Contacts	A	B	Tube Packaging Quantity
DF11- 4DS-2R26(※※)	CL543-0652-0-※※	4	6.0	2.0	188
DF11- 6DS-2R26(※※)	CL543-0653-3-※※	6	8.0	4.0	140
DF11- 8DS-2R26(※※)	CL543-0654-6-※※	8	10.0	6.0	112
DF11-10DS-2R26(※※)	CL543-0655-9-※※	10	12.0	8.0	94
DF11-12DS-2R26(※※)	CL543-0656-1-※※	12	14.0	10.0	80
DF11-14DS-2R26(※※)	CL543-0657-4-※※	14	16.0	12.0	70
DF11-16DS-2R26(※※)	CL543-0658-7-※※	16	18.0	14.0	62
DF11-18DS-2R26(※※)	CL543-0659-0-※※	18	20.0	16.0	56
DF11-20DS-2R26(※※)	CL543-0660-9-※※	20	22.0	18.0	50
DF11-22DS-2R26(※※)	CL543-0661-1-※※	22	24.0	20.0	46
DF11-24DS-2R26(※※)	CL543-0662-4-※※	24	26.0	22.0	42
DF11-26DS-2R26(※※)	CL543-0663-7-※※	26	28.0	24.0	40
DF11-28DS-2R26(※※)	CL543-0664-0-※※	28	30.0	26.0	36
DF11-30DS-2R26(※※)	CL543-0665-2-※※	30	32.0	28.0	34
DF11-32DS-2R26(※※)	CL543-0666-5-※※	32	34.0	30.0	32

Note1: The specific No. "None" item is delivered per bag unit (100 pcs.). Please order products per bag unit.

Note2: To use the full automatic insulation displacement machine to punch the DF11 single contact, the (20) tube packaging specification should be applied.

Note3: Please order the tube packaging products by multiplying the packaging quantity (pcs.).

■Applicable Cable

Product No.	Applicable Cable	Jacket Diameter
DF11-※DS-2R26	UL1061 AWG26 (7/0.16)	φ0.9~1.05mm

■DF11-※DS-2R Insulation Displacement Machine

Type	Product No.	Connection Type	Remarks
Punching full automatic ID machine DF11 single contact	AM700/DF11	<ul style="list-style-type: none"> ■Effective harness form <ol style="list-style-type: none"> 1. DF11-both ended, one ended 2. DF11-DF11, separation 3. DF11-DF3, separation ■Effective harness length 100~2,000mm ■Continuity Inspection Mechanism Equipped 	The connector is applicable to (20) tube packaging.
Desktop ID Machine	SA700/DF11 CL903-0013-5	<ul style="list-style-type: none"> ■Used for DF11 only, No restricted condition 	Desktop machine for small lot

■Crimping Socket

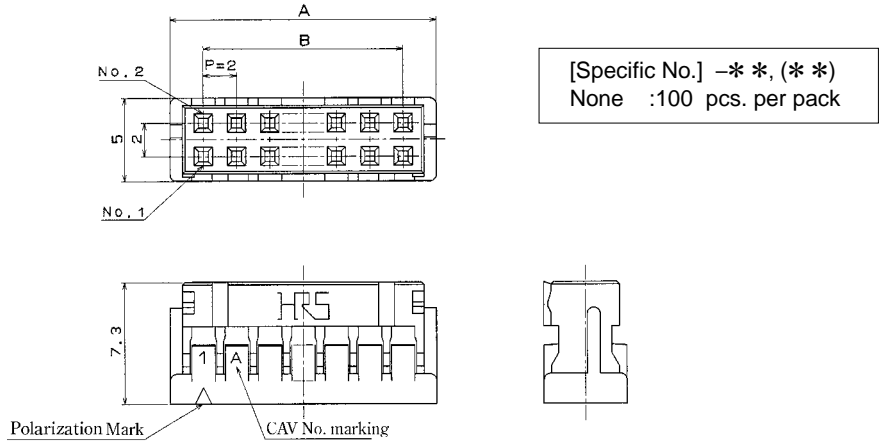
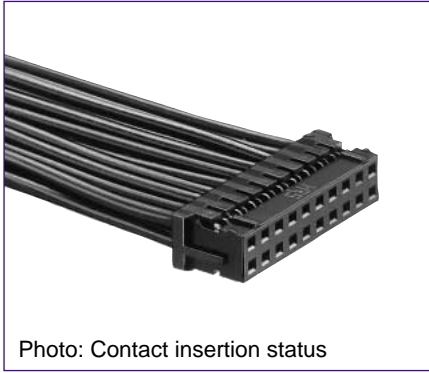

Product No.	HRS No.	Number of Contacts	A	B	Product No.	HRS No.	Number of Contacts	A	B
DF11- 4DS-2C(**)	CL543-0568-6-**	4	6.0	2.0	DF11-20DS-2C(**)	CL543-0509-7-**	20	22.0	18.0
DF11- 6DS-2C(**)	CL543-0502-8-**	6	8.0	4.0	DF11-22DS-2C(**)	CL543-0510-6-**	22	24.0	20.0
DF11- 8DS-2C(**)	CL543-0503-0-**	8	10.0	6.0	DF11-24DS-2C(**)	CL543-0511-9-**	24	26.0	22.0
DF11-10DS-2C(**)	CL543-0504-3-**	10	12.0	8.0	DF11-26DS-2C(**)	CL543-0512-1-**	26	28.0	24.0
DF11-12DS-2C(**)	CL543-0505-6-**	12	14.0	10.0	DF11-28DS-2C(**)	CL543-0513-4-**	28	30.0	26.0
DF11-14DS-2C(**)	CL543-0506-9-**	14	16.0	12.0	DF11-30DS-2C(**)	CL543-0514-7-**	30	32.0	28.0
DF11-16DS-2C(**)	CL543-0507-1-**	16	18.0	14.0	DF11-32DS-2C(**)	CL543-0515-0-**	32	34.0	30.0
DF11-18DS-2C(**)	CL543-0508-4-**	18	20.0	16.0					

Note: The specific No. "None" item is delivered per bag unit (100 pcs.). Please order products bag pack unit.

■Receptacle (DIP)

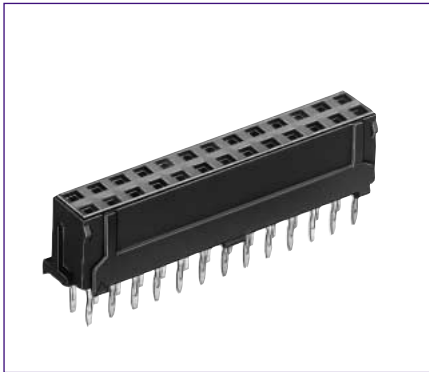

- Board Through-hole Diameter: $\phi 0.8^{+0.1}$
- Kink Prefixed Effective Diameter: $\phi 0.8^{+0.05}$

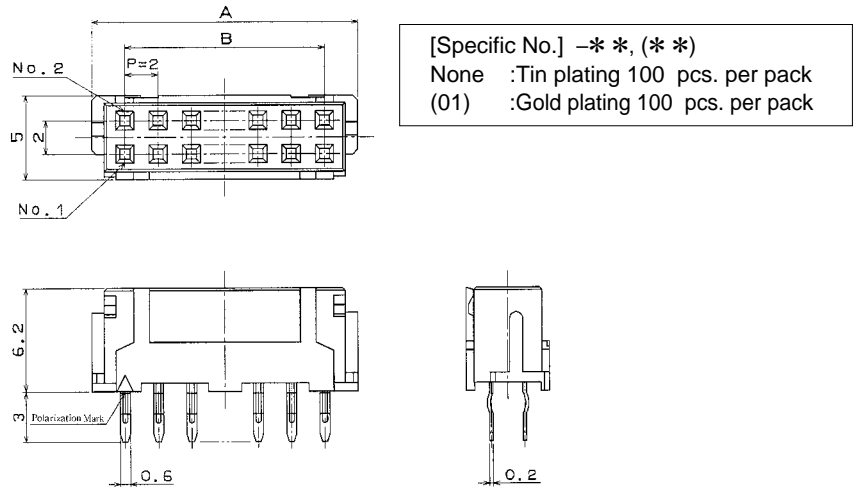

Product No.	HRS No.	Number of Contacts	A	B	Product No.	HRS No.	Number of Contacts	A	B
DF11- 6DS-2DSA(**)	CL543-0553-9-**	6	8.0	4.0	DF11-20DS-2DSA(**)	CL543-0560-4-**	20	22.0	18.0
DF11- 8DS-2DSA(**)	CL543-0554-1-**	8	10.0	6.0	DF11-22DS-2DSA(**)	CL543-0561-7-**	22	24.0	20.0
DF11-10DS-2DSA(**)	CL543-0555-4-**	10	12.0	8.0	DF11-24DS-2DSA(**)	CL543-0562-0-**	24	26.0	22.0
DF11-12DS-2DSA(**)	CL543-0556-7-**	12	14.0	10.0	DF11-26DS-2DSA(**)	CL543-0563-2-**	26	28.0	24.0
DF11-14DS-2DSA(**)	CL543-0557-0-**	14	16.0	12.0	DF11-28DS-2DSA(**)	CL543-0564-5-**	28	30.0	26.0
DF11-16DS-2DSA(**)	CL543-0558-2-**	16	18.0	14.0	DF11-30DS-2DSA(**)	CL543-0565-8-**	30	32.0	28.0
DF11-18DS-2DSA(**)	CL543-0559-5-**	18	20.0	16.0	DF11-32DS-2DSA(**)	CL543-0566-0-**	32	34.0	30.0

Note: The specific No. "None" item is delivered per bag unit (100 pcs.). Please order products per bag unit.

■ Receptacle (SMT)

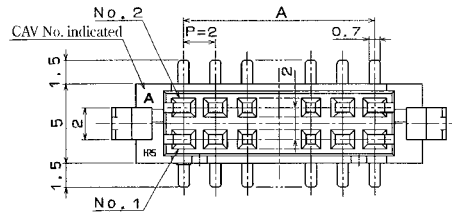
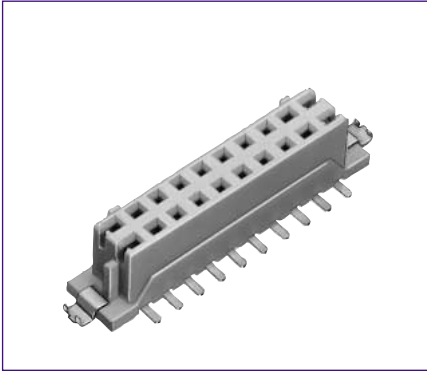

[Specific No.] -* *, (* *)
 (20) : Tin plated tube package product
 (50) : Gold plated tube package product

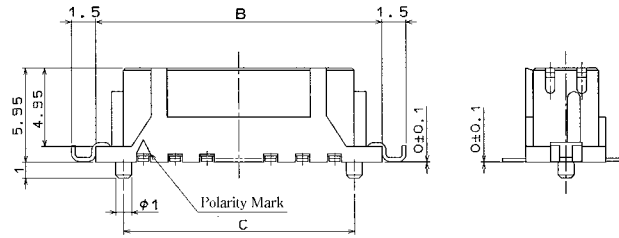

Unit: mm

Product No.	HRS No.	Number of Contacts	A	B	C	D	Tube Package Quantity
DF11- 4DS-2V(***)	CL543-0569-9-***	4	2.0	8.5	4.5	8.7	41pcs.
DF11- 6DS-2V(***)	CL543-0570-8-***	6	4.0	10.5	6.5	10.7	35
DF11- 8DS-2V(***)	CL543-0571-0-***	8	6.0	12.5	8.5	12.7	30
DF11-10DS-2V(***)	CL543-0572-3-***	10	8.0	14.5	10.5	14.7	27
DF11-12DS-2V(***)	CL543-0573-6-***	12	10.0	16.5	12.5	16.7	24
DF11-14DS-2V(***)	CL543-0574-9-***	14	12.0	18.5	14.5	18.7	22
DF11-16DS-2V(***)	CL543-0575-1-***	16	14.0	20.5	16.5	20.7	20
DF11-18DS-2V(***)	CL543-0576-4-***	18	16.0	22.5	18.5	22.7	18
DF11-20DS-2V(***)	CL543-0577-7-***	20	18.0	24.5	20.5	24.7	17
DF11-22DS-2V(***)	CL543-0578-0-***	22	20.0	26.5	22.5	26.7	16
DF11-24DS-2V(***)	CL543-0579-2-***	24	22.0	28.5	24.5	28.7	15
DF11-26DS-2V(***)	CL543-0580-1-***	26	24.0	30.5	26.5	30.7	14
DF11-28DS-2V(***)	CL543-0581-4-***	28	26.0	32.5	28.5	32.7	13
DF11-30DS-2V(***)	CL543-0582-7-***	30	28.0	34.5	30.5	34.7	12
DF11-32DS-2V(***)	CL543-0583-0-***	32	30.0	36.5	32.5	36.7	12
DF11-40DS-2V(***)	CL543-0584-2-***	40	38.0	44.5	40.5	44.7	10

Note1: Please order the tube packaging products, multiplying a tube quantity (pcs.).

Note2: The 40 contacts connector is merchandized only in combination with the SMT product.

◆ Recommended PCB Footprints

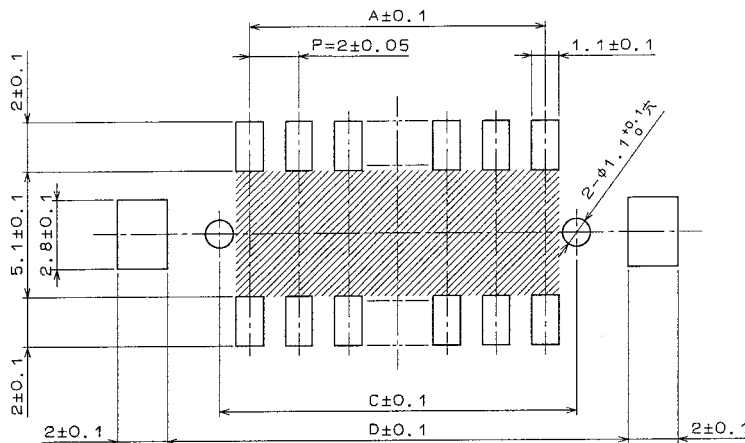

Note: If the pattern is included in the shaded area and not treated with resist, it could touch the connector contact.

◆ Tube Size

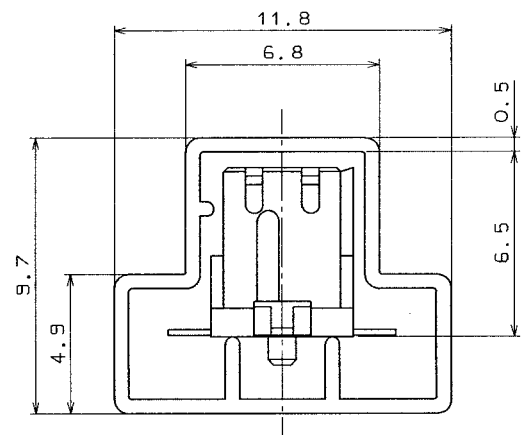

■Straight Pin Header

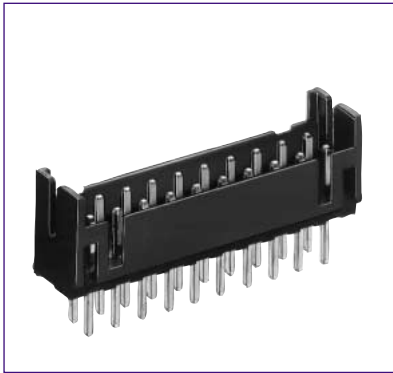

●Board Through-hole Diameter: $\phi 0.8^{+0.1}_0$

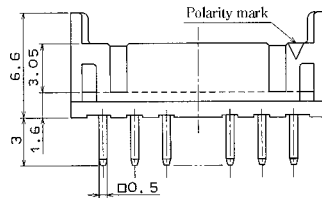
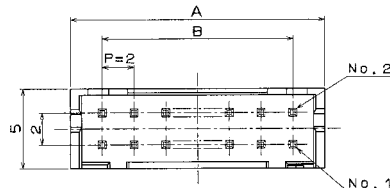

[Specific No.] -** (* *)
 None : Tin plating
 (01) : Gold plating
 (08) : Tin plated row insertion product
 (Tin plating recommended specification)
 (20) : Tin plated tube package product

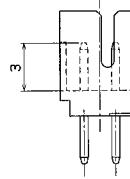

Unit: mm

Product No.	HRS No.	Number of Contacts	A	B	Tube Package Quantity	Product No.	HRS No.	Number of Contacts	A	B	Tube Package Quantity
DF11- 4DP-2DSA(**)	CL543-0517-5-*	4	6.0	2.0	81pcs.	DF11-20DP-2DSA(**)	CL543-0525-3-*	20	22.0	18.0	22pcs.
DF11- 6DP-2DSA(**)	CL543-0518-8-*	6	8.0	4.0	61	DF11-22DP-2DSA(**)	CL543-0526-6-*	22	24.0	20.0	20
DF11- 8DP-2DSA(**)	CL543-0519-0-*	8	10.0	6.0	49	DF11-24DP-2DSA(**)	CL543-0527-9-*	24	26.0	22.0	18
DF11-10DP-2DSA(**)	CL543-0520-0-*	10	12.0	8.0	40	DF11-26DP-2DSA(**)	CL543-0528-1-*	26	28.0	24.0	17
DF11-12DP-2DSA(**)	CL543-0521-2-*	12	14.0	10.0	34	DF11-28DP-2DSA(**)	CL543-0529-4-*	28	30.0	26.0	16
DF11-14DP-2DSA(**)	CL543-0522-5-*	14	16.0	12.0	30	DF11-30DP-2DSA(**)	CL543-0530-3-*	30	32.0	28.0	15
DF11-16DP-2DSA(**)	CL543-0523-8-*	16	18.0	14.0	27	DF11-32DP-2DSA(**)	CL543-0531-6-*	32	34.0	30.0	14
DF11-18DP-2DSA(**)	CL543-0524-0-*	18	20.0	16.0	24						

Note1: Specific No. "None", (01) and (08) items are delivered per bag unit (100 pcs.). Please order products per bagunit.

Note2: Please order the tube packaging products, by mutiplying a tube quantity(pcs.).

■Right Angle Pin Header



●Board Through-hole Diameter: $\phi 0.8^{+0.1}_0$

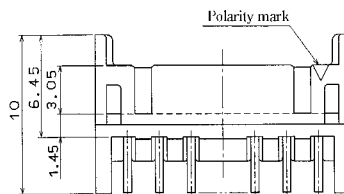
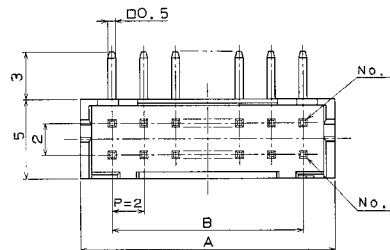

[Specific No.] -** (* *)
 None : Tin plating
 (22) : Gold plating
 (52) : Gold plated tube packaging product
 (24) : Tin plated row insertion product
 (Tin plating recommended specification)

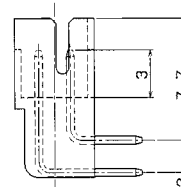

Unit: mm

Product No.	HRS No.	Number of Contacts	A	B	Tube Package Quantity	Product No.	HRS No.	Number of Contacts	A	B	Tube Package Quantity
DF11- 4DP-2DS(**)	CL543-0533-1-*	4	6.0	2.0	81pcs.	DF11-20DP-2DS(**)	CL543-0541-0-*	20	22.0	18.0	22pcs.
DF11- 6DP-2DS(**)	CL543-0534-4-*	6	8.0	4.0	61	DF11-22DP-2DS(**)	CL543-0542-2-*	22	24.0	20.0	20
DF11- 8DP-2DS(**)	CL543-0535-7-*	8	10.0	6.0	48	DF11-24DP-2DS(**)	CL543-0543-5-*	24	26.0	22.0	18
DF11-10DP-2DS(**)	CL543-0536-0-*	10	12.0	8.0	40	DF11-26DP-2DS(**)	CL543-0544-8-*	26	28.0	24.0	17
DF11-12DP-2DS(**)	CL543-0537-2-*	12	14.0	10.0	34	DF11-28DP-2DS(**)	CL543-0545-0-*	28	30.0	26.0	16
DF11-14DP-2DS(**)	CL543-0538-5-*	14	16.0	12.0	30	DF11-30DP-2DS(**)	CL543-0546-3-*	30	32.0	28.0	15
DF11-16DP-2DS(**)	CL543-0539-8-*	16	18.0	14.0	27	DF11-32DP-2DS(**)	CL543-0547-6-*	32	34.0	30.0	14
DF11-18DP-2DS(**)	CL543-0540-7-*	18	20.0	16.0	24						

Note1: Please order the tube packaging product by mutiplying a tube quantity(pcs.).

■Straight Pin Header (SMT)

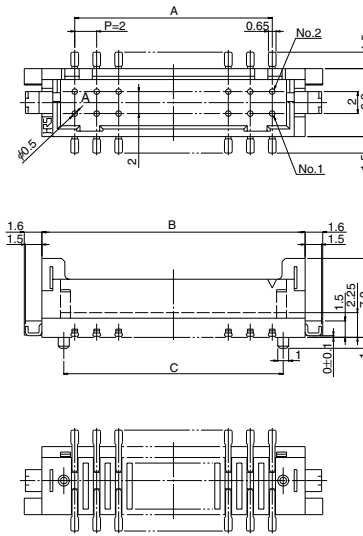
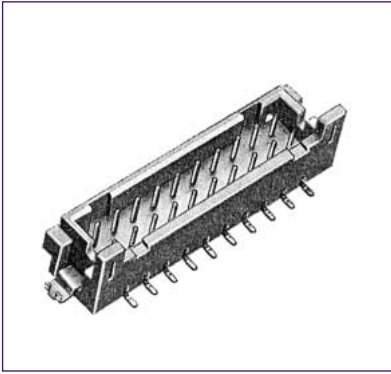

[Specific No.] - * *, (* *)
 (20) : Tin plated tube package product
 (50) : Gold plated tube package product

Unit: mm

Product No.	HRS No.	Number of Contacts	A	B	C	D	Tube Package Quantity
DF11G- 4DP-2V(***)	CL543-0810-0-***	4	2.0	8.5	4.0	8.7	41pcs.
DF11G- 6DP-2V(***)	CL543-0811-2-***	6	4.0	10.5	6.0	10.7	35
DF11G- 8DP-2V(***)	CL543-0812-5-***	8	6.0	12.5	8.0	12.7	30
DF11G-10DP-2V(***)	CL543-0813-8-***	10	8.0	14.5	10.0	14.7	27
DF11G-12DP-2V(***)	CL543-0814-0-***	12	10.0	16.5	12.0	16.7	24
DF11G-14DP-2V(***)	CL543-0815-3-***	14	12.0	18.5	14.0	18.7	22
DF11G-16DP-2V(***)	CL543-0816-6-***	16	14.0	20.5	16.0	20.7	20
DF11G-18DP-2V(***)	CL543-0817-9-***	18	16.0	22.5	18.0	22.7	18
DF11G-20DP-2V(***)	CL543-0818-1-***	20	18.0	24.5	20.0	24.7	17
DF11G-22DP-2V(***)	CL543-0819-4-***	22	20.0	26.5	22.0	26.7	16
DF11G-24DP-2V(***)	CL543-0820-3-***	24	22.0	28.5	24.0	28.7	15
DF11G-26DP-2V(***)	CL543-0821-6-***	26	24.0	30.5	26.0	30.7	14
DF11G-28DP-2V(***)	CL543-0822-9-***	28	26.0	32.5	28.0	32.7	13
DF11G-30DP-2V(***)	CL543-0823-1-***	30	28.0	34.5	30.0	34.7	12
DF11G-32DP-2V(***)	CL543-0824-4-***	32	30.0	36.5	32.0	36.7	12
DF11G-40DP-2V(***)	CL543-0825-7-***	40	38.0	44.5	40.0	44.7	10

Note1: Please order the tube packaging product by multiplying a tube quantity(pcs.).

Note2: The 40 contacts connector is merchandized in combination with the SMT product.

◆Recommended PCB Footprints

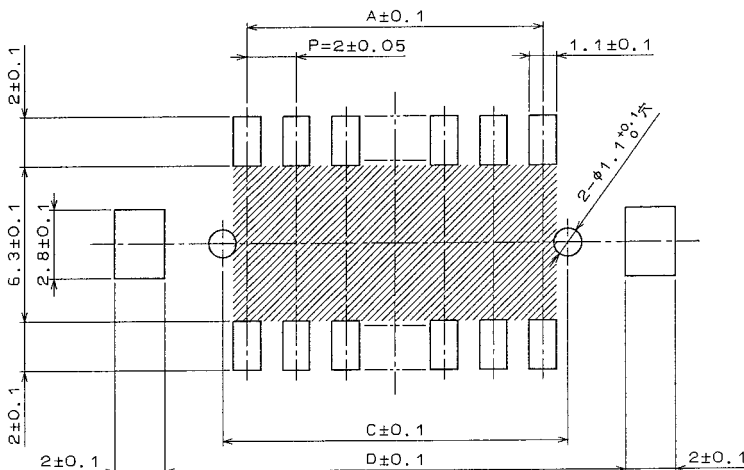

Note: If the pattern is included in the shaded area and not treated with resist, it could contact to the connector contact.

◆Tube Size

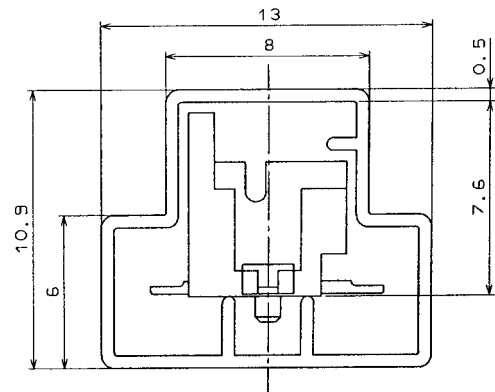

■ In-line Plug

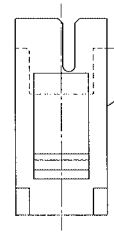
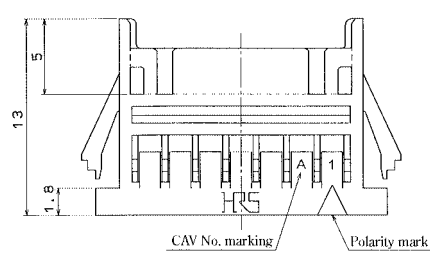
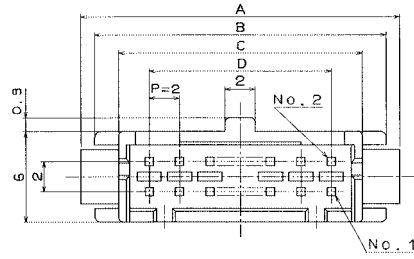
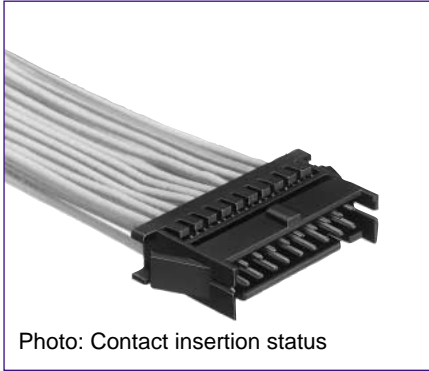

◆ In-line Plug Panel Cutouts

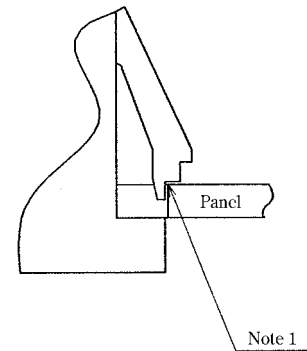
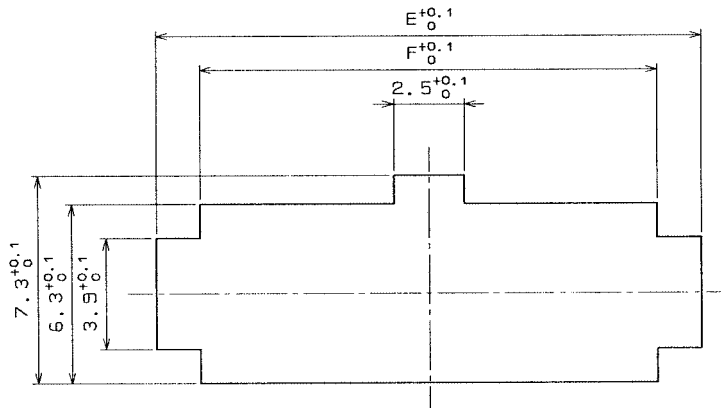

Note1: Please use the non-radius side for the panel hooking area.

Note2: Applicable panel thicknessing is 1.6~1.0mm (A slight deviation will occur for the thickness except for 1.6 and 1.2mm.)

Unit: mm

Product No.	HRS No.	Number of Contacts	A	B	C	D	E	F
DF11- 4DEP-2C(※※)	CL543-0619-5-※※	4	11.0	9.2	6.0	2.0	9.4	6.3
DF11- 6DEP-2C(※※)	CL543-0620-4-※※	6	13.0	11.2	8.0	4.0	11.4	8.3
DF11- 8DEP-2C(※※)	CL543-0621-7-※※	8	15.0	13.2	10.0	6.0	13.4	10.3
DF11-10DEP-2C(※※)	CL543-0622-0-※※	10	17.0	15.2	12.0	8.0	15.4	12.3
DF11-12DEP-2C(※※)	CL543-0623-2-※※	12	19.0	17.2	14.0	10.0	17.4	14.3
DF11-14DEP-2C(※※)	CL543-0624-5-※※	14	21.0	19.2	16.0	12.0	19.4	16.3
DF11-16DEP-2C(※※)	CL543-0625-8-※※	16	23.0	21.2	18.0	14.0	21.4	18.3
DF11-18DEP-2C(※※)	CL543-0626-0-※※	18	25.0	23.2	20.0	16.0	23.4	20.3
DF11-20DEP-2C(※※)	CL543-0627-3-※※	20	27.0	25.2	22.0	18.0	25.4	22.3
DF11-22DEP-2C(※※)	CL543-0628-6-※※	22	29.0	27.2	24.0	20.0	27.4	24.3
DF11-24DEP-2C(※※)	CL543-0629-9-※※	24	31.0	29.2	26.0	22.0	29.4	26.3
DF11-26DEP-2C(※※)	CL543-0630-8-※※	26	33.0	31.2	28.0	24.0	31.4	28.3
DF11-28DEP-2C(※※)	CL543-0631-0-※※	28	35.0	33.2	30.0	26.0	33.4	30.3
DF11-30DEP-2C(※※)	CL543-0632-3-※※	30	37.0	35.2	32.0	28.0	35.4	32.3
DF11-32DEP-2C(※※)	CL543-0633-6-※※	32	39.0	37.2	34.0	30.0	37.4	34.3

[Specific No.] -※※, (※※)
None :100 pcs. per pack

Note1: The specific No. "None" item is delivered per bag unit (100 pcs.). Please order products per bag unit.

■ In-line Adaptor

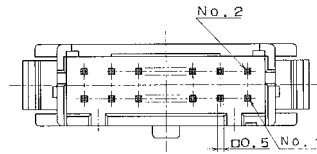
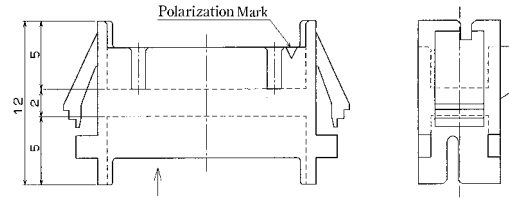
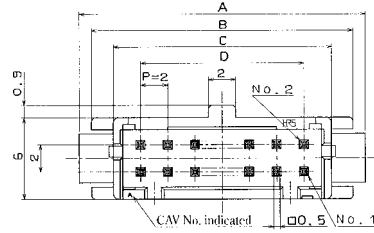
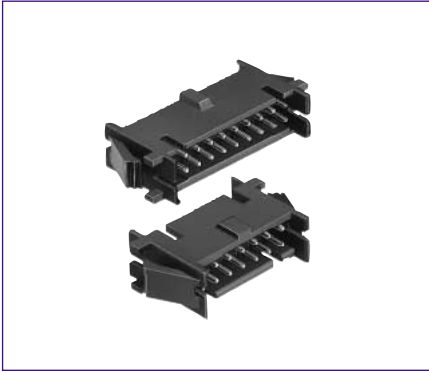

◆ In-line Adaptor Panel Cutouts

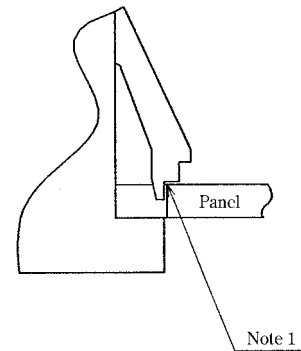
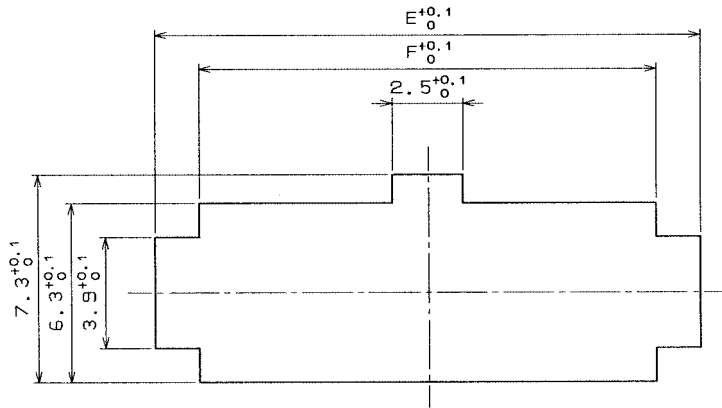

Note1: Please use the non-radius surface in the panel hooking area.

Note2: Applicable panel thickness is 1.6~1.0mm (A slight backlash will occur in the thickness other than 1.6 and 1.2mm.)

Unit: mm

Product No.	HRS No.	Number of Contacts	A	B	C	D	E	F
DF11- 4DEP-2A(***)	CL543-0698-1-***	4	11.0	9.2	6.0	2.0	9.4	6.3
DF11- 6DEP-2A(***)	CL543-0699-4-***	6	13.0	11.2	8.0	4.0	11.4	8.3
DF11- 8DEP-2A(***)	CL543-0700-1-***	8	15.0	13.2	10.0	6.0	13.4	10.3
DF11-10DEP-2A(***)	CL543-0701-4-***	10	17.0	15.2	12.0	8.0	15.4	12.3
DF11-12DEP-2A(***)	CL543-0702-7-***	12	19.0	17.2	14.0	10.0	17.4	14.3
DF11-14DEP-2A(***)	CL543-0703-0-***	14	21.0	19.2	16.0	12.0	19.4	16.3
DF11-16DEP-2A(***)	CL543-0704-2-***	16	23.0	21.2	18.0	14.0	21.4	18.3
DF11-18DEP-2A(***)	CL543-0705-5-***	18	25.0	23.2	20.0	16.0	23.4	20.3
DF11-20DEP-2A(***)	CL543-0706-8-***	20	27.0	25.2	22.0	18.0	25.4	22.3
DF11-22DEP-2A(***)	CL543-0707-6-***	22	29.0	27.2	24.0	20.0	27.4	24.3
DF11-24DEP-2A(***)	CL543-0708-3-***	24	31.0	29.2	26.0	22.0	29.4	26.3
DF11-26DEP-2A(***)	CL543-0709-6-***	26	33.0	31.2	28.0	24.0	31.4	28.3
DF11-28DEP-2A(***)	CL543-0710-5-***	28	35.0	33.2	30.0	26.0	33.4	30.3
DF11-30DEP-2A(***)	CL543-0711-8-***	30	37.0	35.2	32.0	28.0	35.4	32.3
DF11-32DEP-2A(***)	CL543-0712-0-***	32	39.0	37.2	34.0	30.0	37.4	34.3

[Specific No.] -* *, (**)
None :100 pcs. per pack

Note1: The specific No. "None" item is delivered per bag unit (100 pcs.). Please order products per bag unit.

■Crimping Contact for Socket

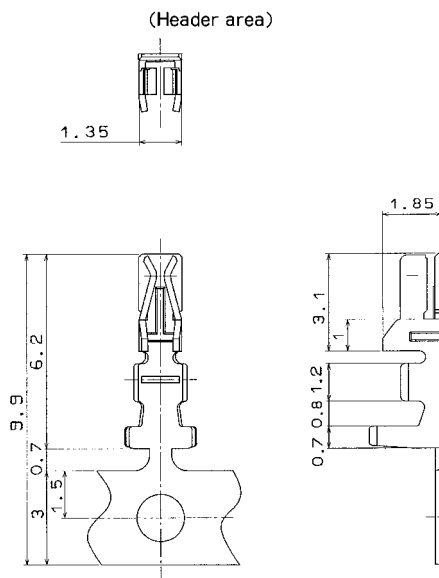

Product No.	HRS No.	Type	Quantity	Finish
DF11-22SCF	CL543-0601-0	Reel contact	10000 pcs. per reel	Tin plating
DF11-22SC	CL543-0602-2	Bulk contact	100 pcs. per bag	
DF11-2428SCF	CL543-0500-2	Reel contact	10000 pcs. per reel	
DF11-2428SC	CL543-0501-5	Bulk contact	100 pcs. per bag	
DF11A-2428SCF	CL543-0634-9	Reel contact	10000 pcs. per reel	
DF11A-2428SC	CL543-0635-1	Bulk contact	100 pcs. per bag	
DF11-30SCF	CL543-0605-0	Reel contact	10000 pcs. per reel	Gold plating
DF11-30SC	CL543-0606-3	Bulk contact	100 pcs. per bag	
DF11-22SCFA	CL543-0603-5	Reel contact	10000 pcs. per reel	
DF11-22SCA	CL543-0604-8	Bulk contact	100 pcs. per bag	
DF11-2428SCFA	CL543-0550-0	Reel contact	10000 pcs. per reel	
DF11-2428SCA	CL543-0551-3	Bulk contact	100 pcs. per bag	
DF11-30SCFA	CL543-0607-6	Reel contact	10000 pcs. per reel	Gold plating
DF11-30SCA	CL543-0608-9	Bulk contact	100 pcs. per bag	

Note1: DF11A-2428SCF/SC is of tin plated low insertion/extraction type.

●Applicable Wire (Tin Plated Annealed Copper Wire)

Conductor Size (Wire Structure)	Jacket Diameter
AWG 22 (17pcs./0.16mm)	$\phi 1.2 \sim \phi 1.45 \text{mm}$
AWG 24 (11pcs./0.16mm)	$\phi 0.9 \sim \phi 1.45 \text{mm}$
AWG 26 (7pcs./0.16mm)	
AWG 28 (7pcs./0.127mm)	
AWG 30 (7pcs./0.1mm)	$\phi 0.75 \sim \phi 1.2 \text{mm}$

●Recommended Wire

UL1061, UL1007 (Note 2.)

●Strip Length

1.7~2.3mm

Note1: If other wires are used than the applicable wire, consult the HRS sales department.

Note2: DF11-22SCF/SC/SCFA/SCA is for UL1061.

■Crimping Contact for In-line Plug

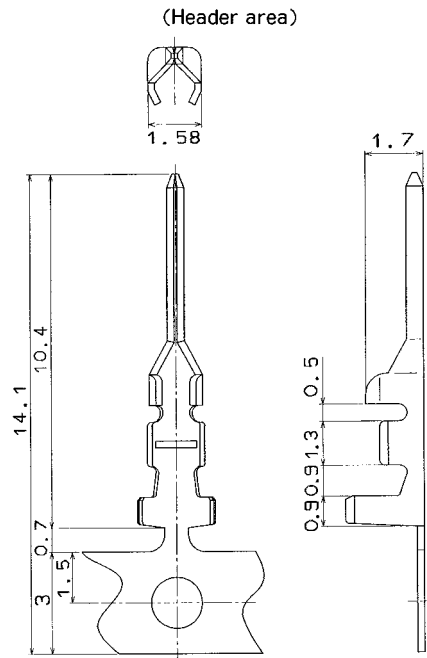

Product No.	HRS No.	Type	Quantity	Finish
DF11EP2428PCF	CL543-0615-4	Reel contact	10000 pcs. per reel	Tin plating
DF11EP2428PC	CL543-0616-7	Bulk contact	100 pcs. per bag	
DF11EP2428PCFA	CL543-0617-0	Reel contact	10000 pcs. per reel	Gold plating
DF11-EP2428PCA	CL543-0618-2	Bulk contact	100 pcs. per bag	

●Applicable Wire (Tin Plated Annealed Copper Wire)

Conductor Size (Contact Wire Structure)	Jacket Diameter
AWG 24 (11pcs./0.16mm)	$\phi 0.9 \sim \phi 1.45 \text{mm}$
AWG 26 (7pcs./0.16mm)	
AWG 28 (7pcs./0.127mm)	

●Recommended Wire

UL1061, UL1007

●Strip Length

1.9~2.3mm

Note1: If other wires are used than the applicable wire, consult the HRS sales department.

◆Applicable Crimping Tool

Type	Product No.	HRS No.	Applicable Contact
Applicator	AP105-DF11-22S	CL901-4529-7	DF11 -22SCF/SCFA
	AP105-DF11-2428S	CL901-4511-1	DF11 -2428SCF/SCFA DF11A-2428SCF
	AP105-DF11-30S	CL901-4532-1	DF11 -30SCF/SCFA
	AP105-DF11-EP2428P	CL901-4528-4	DF11 -EP2428PCF/PCFA
Press Unit	CM-105	CL901-0005-4	_____
Hand Crimping Tool	DF11-TA22HC	CL550-0228-6	DF11 -22SC/SCA
	DF11-TA2428HC	CL550-0197-4	DF11 -2428SC/SCA DF11A-2428SC
	DF11-TA30HC	CL550-0230-8	DF11 -30SC/SCA
	DF11EP-TA2428HC	CL550-0227-3	DF11 -EP2428PC/PCA
Extraction Tool	DF-C-PO(B)	CL550-0179-2	DF11 -****SCF DF11 -EP****PCF

Note: If any trouble has occurred due to tools other than the designated tool, Hirose bears no responsibility for any trouble.

◆ Application Pattern

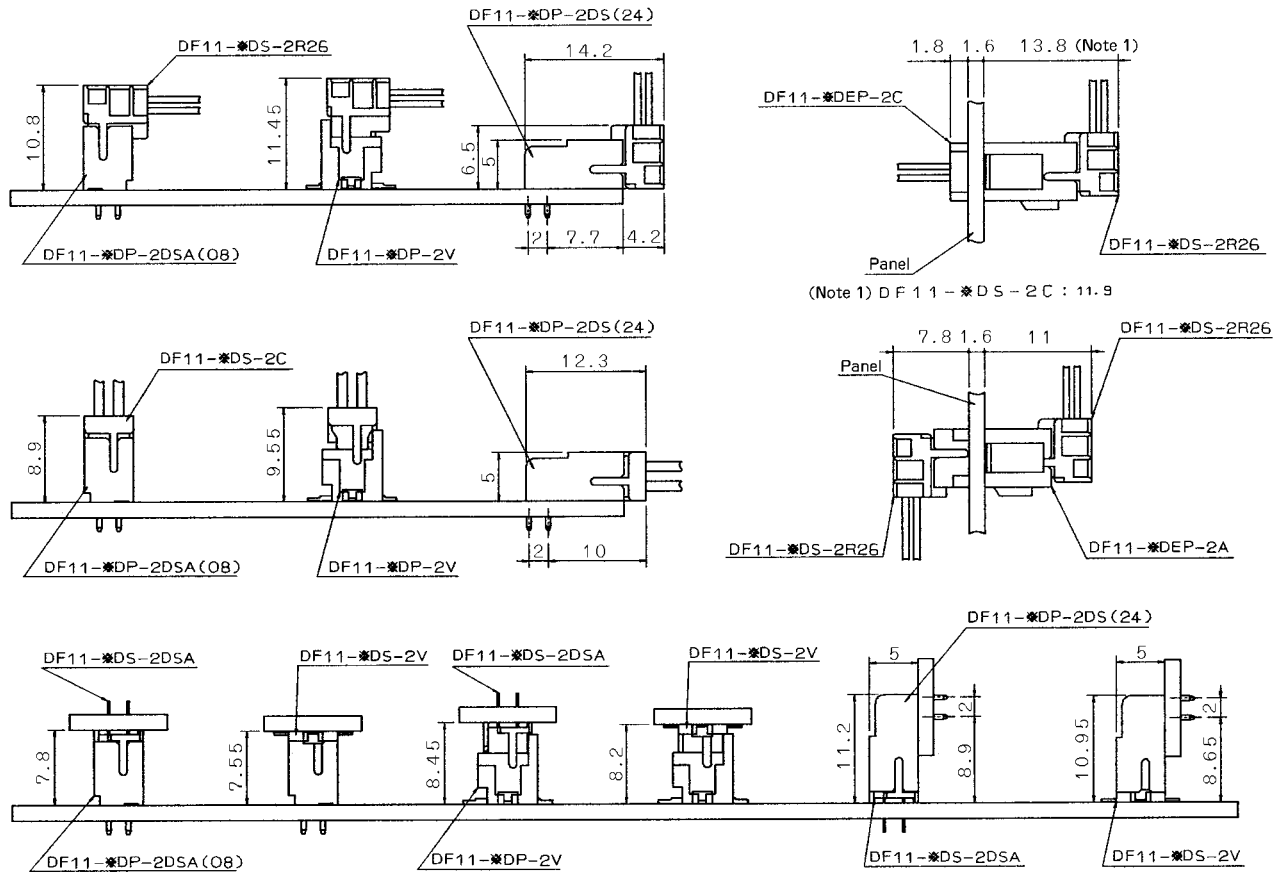

◆ Precautions for Use

<p>1. Recommended Temperature Profile (SMT)</p>	<p>IR reflow condition</p> <ul style="list-style-type: none"> Preheating area 150°C for 100~120 seconds Soldering area 235±5°C for 10 seconds max, 220°C Min for 10~30 seconds <p>Max 240°C 220°C</p> <p>Note1: Maximum twice action is allowed under the same condition. However, the interval between first and second actions must be maintained at the room temperature.</p> <p>Note2: The temperature indicates the board surface temperature in the connector lead area.</p>
<p>2. Recommended Manual Soldering Condition (SMT)</p>	<p>Soldering iron temperature: 290±10°C, Soldering time: Within 2 seconds</p>
<p>3. Recommended Screen Thickness (SMT)</p>	<p>0.15~0.2mm</p>
<p>4. Board Warp age (SMT)</p>	<p>Based on the both connector edges, 0.03mm max. is allowed in the connector center area.</p>
<p>5. Recommended Soldering Condition (DIP)</p>	<p>■ Flow Condition by Automatic Soldering Tool: Soldering temperature: 250±5°C, Soldering time: Within 3 seconds</p>
<p>6. Cleaning Condition</p>	<p>■ Manual Soldering Condition: Soldering iron temperature: 290±10°C, Soldering time: Within 2 seconds</p>
<p>7. Connection Condition</p>	<p>Refer to the "Nylon Connector Instruction Manual".</p>
<p>7. Connection Condition</p>	<p>Refer to the "Nylon Connector Instruction Manual".</p>